

ISO/TC 156

Secretariat: SAC

Voting begins on:  
2014-09-15

Voting terminates on:  
2014-11-15

---

---

## Corrosion of metals and alloys — Test method for high temperature corrosion testing of metallic materials by immersing in molten salt or other liquids under static conditions

*Corrosion des métaux et alliages — Méthode d'essai pour essais  
de corrosion à haute température de matériaux métalliques par  
immersion dans le sel fondu ou autres liquides dans des conditions  
statiques*

RECIPIENTS OF THIS DRAFT ARE INVITED TO SUBMIT, WITH THEIR COMMENTS, NOTIFICATION OF ANY RELEVANT PATENT RIGHTS OF WHICH THEY ARE AWARE AND TO PROVIDE SUPPORTING DOCUMENTATION.

IN ADDITION TO THEIR EVALUATION AS BEING ACCEPTABLE FOR INDUSTRIAL, TECHNOLOGICAL, COMMERCIAL AND USER PURPOSES, DRAFT INTERNATIONAL STANDARDS MAY ON OCCASION HAVE TO BE CONSIDERED IN THE LIGHT OF THEIR POTENTIAL TO BECOME STANDARDS TO WHICH REFERENCE MAY BE MADE IN NATIONAL REGULATIONS.



Reference number  
ISO/FDIS 17245:2014(E)



**COPYRIGHT PROTECTED DOCUMENT**

© ISO 2014

All rights reserved. Unless otherwise specified, no part of this publication may be reproduced or utilized otherwise in any form or by any means, electronic or mechanical, including photocopying, or posting on the internet or an intranet, without prior written permission. Permission can be requested from either ISO at the address below or ISO's member body in the country of the requester.

ISO copyright office  
Case postale 56 • CH-1211 Geneva 20  
Tel. + 41 22 749 01 11  
Fax + 41 22 749 09 47  
E-mail [copyright@iso.org](mailto:copyright@iso.org)  
Web [www.iso.org](http://www.iso.org)

Published in Switzerland

# Contents

	Page
<b>Foreword</b> .....	<b>iv</b>
<b>Introduction</b> .....	<b>v</b>
<b>1 Scope</b> .....	<b>1</b>
<b>2 Normative references</b> .....	<b>1</b>
<b>3 Terms and definitions</b> .....	<b>2</b>
<b>4 Test method</b> .....	<b>2</b>
4.1 Principle.....	2
4.2 Reagents and materials.....	2
4.3 Test apparatus.....	3
4.4 Procedure.....	5
4.5 Determination of mass change.....	7
<b>5 Examination of surface and microstructure of corroded test pieces</b> .....	<b>8</b>
<b>6 Report</b> .....	<b>8</b>
6.1 Matters to be described.....	8
<b>Annex A (informative) Chemical and electrolytic procedures for removal of corrosion products</b> ..	<b>10</b>
<b>Bibliography</b> .....	<b>13</b>

## Foreword

ISO (the International Organization for Standardization) is a worldwide federation of national standards bodies (ISO member bodies). The work of preparing International Standards is normally carried out through ISO technical committees. Each member body interested in a subject for which a technical committee has been established has the right to be represented on that committee. International organizations, governmental and non-governmental, in liaison with ISO, also take part in the work. ISO collaborates closely with the International Electrotechnical Commission (IEC) on all matters of electrotechnical standardization.

The procedures used to develop this document and those intended for its further maintenance are described in the ISO/IEC Directives, Part 1. In particular the different approval criteria needed for the different types of ISO documents should be noted. This document was drafted in accordance with the editorial rules of the ISO/IEC Directives, Part 2 (see [www.iso.org/directives](http://www.iso.org/directives)).

Attention is drawn to the possibility that some of the elements of this document may be the subject of patent rights. ISO shall not be held responsible for identifying any or all such patent rights. Details of any patent rights identified during the development of the document will be in the Introduction and/or on the ISO list of patent declarations received (see [www.iso.org/patents](http://www.iso.org/patents)).

Any trade name used in this document is information given for the convenience of users and does not constitute an endorsement.

For an explanation on the meaning of ISO specific terms and expressions related to conformity assessment, as well as information about ISO's adherence to the WTO principles in the Technical Barriers to Trade (TBT) see the following URL: Foreword - Supplementary information

The committee responsible for this document is ISO/TC 156, *Corrosion of metals and alloys*, Working Group 13, *High Temperature Corrosion*.

## Introduction

In contrast to high temperature corrosion occurring in gaseous environment covered in ISO 21608 and ISO 13573, this International Standard focuses on high temperature corrosion occurring on materials that are in direct contact with molten corrosive substances.

The present document considers the case of a metallic material immersed completely in a corrosive substance that either melts during high temperature exposure or that is liquid throughout the experiment.

The closely-related condition involving exposure in a compacted powder is described in ISO 17248:—<sup>1)</sup> and that involving application of a surface deposit of salt, ash, or other substances in ISO 17224:—<sup>1)</sup>.

---

1) To be published.



# Corrosion of metals and alloys — Test method for high temperature corrosion testing of metallic materials by immersing in molten salt or other liquids under static conditions

## 1 Scope

This International Standard specifies the method for high temperature corrosion testing of metallic materials by immersing in molten salt or other liquids which are under static conditions and exposing them to high temperature in a controlled gas environment to evaluate their corrosion resistance.

Two options are considered

- a) using a stagnant inert gas environment, and
- b) using a flowing reactive gas environment.

This International Standard does not cover methods where test pieces are fully or partially embedded in a corrosive powder made up of salt, ash, and/or other solids, or cases in which a surface deposit is applied to the specimens. These methods are covered in ISO 17248:—<sup>2)</sup> and ISO 17224:—<sup>2)</sup>, respectively.

This International Standard is not applicable to the situation of test pieces in relative movement to their surrounding corrosive liquid.

NOTE This situation is intended to be dealt with in a future International Standard.

## 2 Normative references

The following documents, in whole or in part, are normatively referenced in this document and are indispensable for its application. For dated references, only the edition cited applies. For undated references, the latest edition of the referenced document (including any amendments) applies.

ISO 3611, *Geometrical product specifications (GPS) — Dimensional measuring equipment: Micrometers for external measurements — Design and metrological characteristics*

ISO 6906, *Vernier callipers reading to 0,02 mm*

ISO 8044:—<sup>2)</sup>, *Corrosion of metals and alloys — Basic terms and definitions*

ISO 8407, *Corrosion of metals and alloys — Removal of corrosion products from corrosion test specimens*

ISO 26146, *Corrosion of metals and alloys — Method for metallographic examination of samples after exposure to high-temperature corrosive environments*

ISO 21608, *Corrosion of metals and alloys — Test method for isothermal-exposure oxidation testing under high-temperature corrosion conditions for metallic materials*

ASTM E220, *Standard method for calibration of thermocouples by comparison techniques*

ASTM E230, *Standard temperature-electromotive forces tables for standardized thermocouples*

ASTM E1350, *Standard test method for testing sheathed thermocouples prior to, during and after installation*

---

2) To be published.

### 3 Terms and definitions

For the purposes of this document, the terms and definitions given in ISO 8044:—<sup>3)</sup> and the following apply.

#### 3.1 affected layer

layer beneath the test piece surface that is affected in its composition and/or structure due to corrosion

#### 3.2 corrosive liquid

powder mixture made up of salt, ash, and/or other solids that will melt under the experimental temperature or liquid that contains compounds that are expected to react with the metal at high temperature

#### 3.3 controlled gas environment

flowing gas mixture of defined composition and flow rate which can affect the behaviour of the corrosive liquid

#### 3.4 descaling

removal of corrosion products and corrosive phases from the test piece surface before measurement of the mass of the remaining metal

### 4 Test method

#### 4.1 Principle

The test shall be performed with at least three test pieces of each material to ensure reproducibility of the test results. These test pieces can be used for determination of mass change, dimensional changes, and/or for observation of the surface and/or cross section.

#### 4.2 Reagents and materials

##### 4.2.1 Test pieces

The test pieces shall have the form of a rectangular plate, a disc, or a cylinder with a minimum surface area of 300 mm<sup>2</sup> and a minimum thickness of 1,5 mm.

If the test pieces cannot be made according to these specifications, the shape and dimensions of the test pieces shall be in accordance with the agreement between the parties involved.

The test pieces shall be machined to remove the strata affected by cutting.

The final finishing of the surface of the test pieces shall be performed with abrasives with mean particle diameter of approximately 15 µm. This can be achieved by the use of abrasives according to [Table 1](#).

---

3) To be published.



**Table 1 — Designation and mean diameter of particles of coated abrasives according to regional standards**

Standard	Designation	Mean diameter μm	Region
FEPA <sup>a</sup> 43-1984 R 1993: Grit Sizes for Coated Abrasives ISO 6344 Coated abrasives - Grain size analysis	P1200	15,3 ± 1,0	Europe
JIS R6001-87	#1000	15,5 ± 1,0	Japan
ANSI B74.12-92 — Specifications for the size of abrasive grain - Grinding wheels, polishing and general industrial uses	600	16,0	America
<sup>a</sup> Federation of European Producers of Abrasives			

If another surface finish is required by the parties involved, the surface finish condition shall be described.

Sharp edges of test pieces might give anomalous behaviour. These shall be slightly rounded during the final stages of test piece preparation.

The dimensions of the test pieces shall be measured prior to exposure at a minimum of three positions for each dimension with a precision of ±0,02 mm by means of the measuring instruments specified in ISO 3611 and ISO 6906.

After ultrasonically degreasing in isopropanol or ethanol, the test pieces shall be dried in hot air or in a desiccator.

If it is suspected that test pieces might absorb significant amounts of atmospheric contaminants such as water, it is recommended that the cleaned test pieces are stored in a desiccator prior to weighing and exposure.

The mass of the test pieces shall be determined prior to exposure. At least two measurements shall be made for each test piece. The difference between the measurements shall not exceed 0,05 mg.

#### 4.2.2 Corrosive substance

The type of corrosive substance to be used in the test shall be selected in accordance with the environment for which the test is intended. It shall be prepared either by taking deposit from actual equipment or by mixing chemicals of reagent grade.

The prepared substance shall be mixed well to make it homogeneous. The melting range of the substance shall be measured in advance if it is not known, or it shall be determined from phase diagrams in order to ensure that the liquid phase is the major component.

**WARNING — When working with dangerous substances (such as certain ashes and molten salts), all necessary safety precautions shall be taken.**

### 4.3 Test apparatus

#### 4.3.1 Design of apparatus

The apparatus shall be composed, as a whole, of the temperature regulating device for heating all test pieces at a uniform temperature. The heating device shall be equipped with a testing portion capable of separating the test pieces from outside air (closed system).

A basic design of a closed, horizontal apparatus is shown in [Figure 1](#). Other designs can use vertical orientation. A design of the complete furnace setup is shown in Figure 1 of ISO 21608.

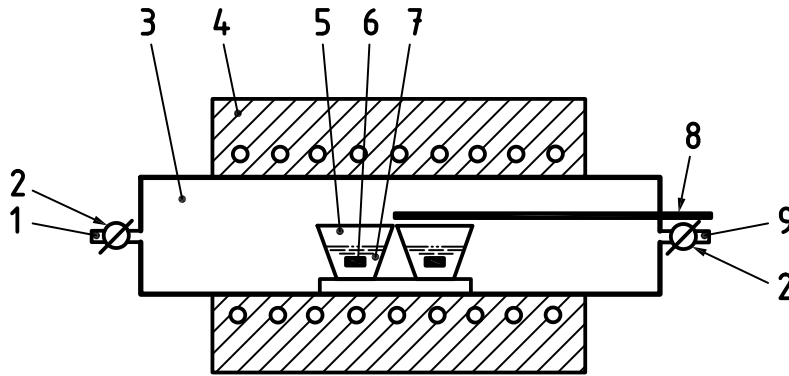

**Key**

- 1 test gas inlet
- 2 overpressure valve
- 3 test chamber
- 4 heating unit
- 5 crucible
- 6 test piece
- 7 corrosive substance
- 8 thermocouple
- 9 gas exit

**Figure 1 — Closed apparatus using a horizontal furnace**

The test chamber shall not be composed of materials that react significantly with the gas environment or the corrosive substance during the test. If the reaction is not avoidable, the reaction shall be small enough to neglect a change in composition of the atmosphere.

NOTE Condensation can be an issue, which can be addressed by heating flanges or ensuring that the ratio of total crucible volume to chamber volume is 1:10.

**4.3.2 Stagnant inert gas environment**

The test chamber shall be filled with a gas that is inert to the corrosive substance prior to the test and then closed. An overpressure valve should be used in order to maintain the pressure of the system at desired pressure.

**4.3.3 Flowing reactive gas environment**

The gas supply system shall be capable of supplying the test gases at a constant flow rate to the test piece chamber described in [4.3.1](#).

When a humidifying regulator is used, it shall be capable of adjusting to the desired humidity. Deionized water of electrical conductivity less than 1  $\mu\text{S cm}^{-1}$  shall be used.

The gas line between humidifying regulator and test chamber shall be kept above the dew point in order to avoid condensation.

The gas flow shall be monitored by a gas flow meter. The flow meter shall be located as close as possible to the inlet of the test chamber except where a humidifying regulator is used, in which case it shall be located upstream from the humidifier.

In the case that the gas is humidified, the water vapour content shall be measured. This can be achieved by, e.g. the use of a hygrometer before the test chamber or by measuring the amount of water after

condensation of the exhaust gases or by measuring the water consumption of the humidifier over the course of the experiment.

#### 4.3.4 Temperature monitoring

The temperature distribution of the furnace shall be characterized at the exposure temperature prior to the testing to determine the width of the isothermal zone by the use of a movable thermocouple.

The temperature regulating device shall be capable to guarantee that the temperature of the test piece is kept within the permissible range given in [Table 2](#).

**Table 2 — Permissible tolerance of temperature of test pieces**

Temperature range, °C	≤300	300 to 600	600 to 800	800 to 1 000	1 000 to 1 200	>1 200
Temperature tolerance, °C	±2	±3	±4	±5	±7	By agreement

Thermocouple sheaths shall be used to protect the thermocouple wires. The thermocouple sheaths shall withstand fully the test temperature and environment.

A specimen thermocouple shall be positioned as close as possible to the crucibles. The temperature of the test piece shall be deduced from the furnace calibration using dummy test pieces in an appropriate environment under thermal equilibrium.

Calibration of thermocouples shall be performed in accordance with ASTM E220, ASTM E230, and ASTM E1350. A representative thermocouple taken from the batch of wire can be calibrated.

Thermocouples shall be recalibrated annually or at the beginning and the end of each experiment, if there is uncertainty about thermocouple stability.

## 4.4 Procedure

### 4.4.1 Preparation and placement of the test piece

The crucible shall be inert to the environment.

The configuration of the test piece in an alumina, silica, or zirconia crucible, depending on the acidic or basic character of the corrosive substance, is shown in [Figure 2](#).

Crucibles shall be baked in air to remove volatile compounds before their first use. The recommended baking conditions are at least 24 h at a temperature of 1 000 °C. If water absorption is suspected to have occurred, used crucibles shall be dried at significantly above 100 °C.

The amount of corrosive substance in each crucible shall be at least 20 ml per 1 cm<sup>2</sup> of the surface area of a test piece. The corrosive substance shall be placed in a manner that the depth between the surface of the corrosive substance and the surface of the test piece will be at least 5 mm in the liquid phase.

The volume shrinkage of the corrosive substance during melting shall be determined in a separate test using the same powder loading procedure as will be used in the corrosion test.

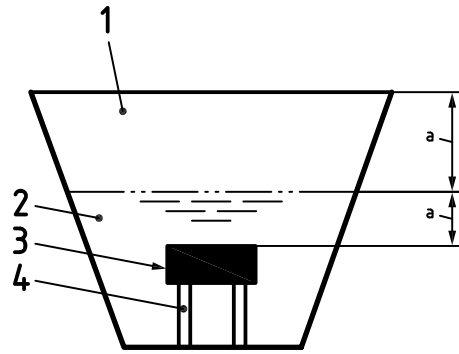

**Key**

- 1 crucible
- 2 corrosive substance
- 3 test piece
- 4 test piece support
- a Minimum of 5 mm.

**Figure 2 — Test piece immersed in corrosive substance**

**4.4.2 Test environment with flowing reactive gas**

If a flowing reactive gas is used, the composition of the test gas shall be chosen in a way that it keeps the corrosive activity of the corrosive liquid stable.

The flow rate of the test gas shall be so high as to fill the test chamber at least three times in an hour. This is to ensure that the corrosion rate is not determined by the supply of the reactants.

The gas flow shall be preheated to reach equilibrium in the gas phase. An appropriate catalyst shall be used, if necessary.

**4.4.3 Heating method**

The test pieces in their crucibles shall be placed in the furnace at room temperature, and heating shall be carried out in the test gas. The time to reach the test temperature shall be recorded.

If heating in the test gas is not acceptable from a safety perspective, heating shall be performed in a gas similar in composition to the test gas but with the critical components absent until a temperature has been reached, at which point, the safety concerns have been resolved.

Heating shall be carried out using as fast a heating rate as possible, up to the temperature of 30 °C below the liquidus temperature of the corrosive substance. Further heating shall be conducted at a slower rate (e.g. 2 °C per minute) up to the temperature of 30 °C above the liquidus temperature of the corrosive substance. A fast heating rate can then be used to achieve the test temperature.

**NOTE** In certain set-ups, a fast heating rate is not possible because the heating rate can be harmful to ceramic components, such as heating elements and reaction tubes.

In the case of humidified atmospheres, the humidification shall not be started until the temperature in the coldest part of the test chamber exceeds the dew point of possible condensing phases.

The heating shall be carried out in a manner that the temperature of test pieces does not exceed the upper limit of permissible temperatures listed in [Table 2](#).

#### 4.4.4 Test duration

The test is defined to commence when the test piece temperature exceeds 97 % of the desired test temperature  $T_{\text{dwell}}$  (measured in K).

The test ends when the temperature of the test piece falls below 97 % of the desired test temperature  $T_{\text{dwell}}$  (measured in K).

The test duration shall be relevant to the intended application and agreed upon between the parties concerned. The materials' behaviour observed in short-term exposures might not continue at long durations, therefore, for testing of relevance to long-term service conditions, the entire exposure time shall be at least 300 h.

#### 4.4.5 Cooling of test pieces

Depending on requirements, the test pieces can be cooled in the furnace, or they can be removed and the corrosive liquid decanted from the crucible. In the latter case, a dry purge gas atmosphere shall be applied for a sufficient duration before opening the furnace in order to avoid any harmful reactions with air at elevated temperature. If furnace cooling is used, it shall be carried out in the test gas down to 200 °C and the time to cool to 50 °C shall be recorded. In the case of humidified atmospheres, the humidification shall be stopped before the temperature in the coldest part of the test chamber falls below 200 °C.

If cooling in the test gas is not acceptable from a safety perspective, cooling shall be performed in a gas similar in composition to the test gas but with the critical components absent.

**SAFETY PRECAUTIONS — All necessary health and safety requirements should be met when handling hot corrosive liquids.**

The solidified substance attached to the test piece surface after cooling shall be removed using a stripping solution. Normally, hydrochloric acid (concentrated) solution can be used for this purpose.

### 4.5 Determination of mass change

#### 4.5.1 Principle

One method to determine corrosion kinetics is to measure mass change. Duplicate test pieces of each material shall be used. Test pieces should be weighed as soon as possible or shall be stored in a desiccator after removal from the furnace until immediately before weighing. When handling test pieces, tweezers shall be used. Test pieces shall never be touched with hands to avoid contamination (e.g. grease, salts). Care has to be taken when using gloves as the contamination with the separating agent of the gloves leads to falsification in mass determination. If repeated measurements are not consistent, the temperature and humidity of the weighing environment has to be controlled.

#### 4.5.2 Measurements prior to testing

The mass of the test pieces shall be determined prior to exposure [ $m_T(t_0)$ , see Figure 5 in ISO 21608]. At least two individual measurements shall be made for each test piece with a precision of 0,02 mg. The maximum difference between the measurements shall not exceed  $\pm 0,05$  mg.

#### 4.5.3 Descaling prior to mass determination

If descaling prior to mass determination is intended, all corrosion products shall be removed from test pieces with a minimum removal of sound metal. This shall be done according to ISO 8407.

Additional procedures are given in [Annex A](#) (see [Table A.1](#) and [Table A.2](#)).

NOTE These procedures are not suitable to remove internal corrosion products as defined in ISO 26146.

#### **4.5.4 Measurement of corrosion mass loss**

The mass loss of the test pieces due to corrosion shall be determined according to ISO 8407.

### **5 Examination of surface and microstructure of corroded test pieces**

Metallographic examination shall be made of the surface and cross section. Detailed procedures for examinations are provided in ISO 26146.

## **6 Report**

### **6.1 Matters to be described**

The following data, where known, shall be included in the report on the test results.

#### **6.1.1 Test material**

- a) Manufacturer
- b) Name of material (manufacturer designation; ASTM, DIN etc.)
- c) Grade or symbol
- d) Heat number / Batch number
- e) Chemical composition (analysis technique)
- f) Processing condition
- g) Heat treatment condition
- h) Microstructure of the material determined according to ASTM E3 and etching according to ASTM E407

#### **6.1.2 Test piece**

- a) Designation of test piece
- b) Sampling conditions of the test piece from raw material (crystallographic orientation, rolling direction etc.)
- c) Dimensions (in mm) and surface area  $A$  (in  $\text{cm}^2$ ) of test piece
- d) Surface finish condition of test piece
- e) Degreasing method of test piece
- f) Initial mass

#### **6.1.3 Testing environments**

- a) Test temperature
- b) Characteristic heating and cooling curves of the test piece in the corrosive substance
- c) Test duration
- d) Volume of test chamber
- e) Stagnant inert gas environment or flowing reactive gas environment according to [4.3.2](#) and [4.3.3](#)

- f) Composition of test gas including humidity
- g) Volumetric flow rate of test gas in normal cubic meters per second
- h) Chemical composition, melting point, water content, preparation method, and origin of the corrosive substance
- i) Amount of corrosive substance used per crucible
- j) Size, type, and material of the crucibles used

#### 6.1.4 Test results

- a) Mass loss caused by descaling procedures according to [4.5.3](#).
- b) Mass loss caused by the corrosion experiment according to [4.5.4](#).
- c) In case of determination of corrosion kinetics: mass loss  $\Delta m$  divided by surface area  $A$  as a function of time.
- d) Image of appearance after testing.
- e) Image of cross section including the surface layer of the metallographic section of test piece after testing. The chosen magnifications must clearly show the extent of the total attack in a single micrograph.
- f) Results of any metallographic investigations performed according to 5.
- g) Results of analysis of corrosive substance after long-term exposure, if performed according to [4.2.2](#).

#### 6.1.5 Supplementary note

It is desirable to describe the following matters in the report on the test results:

- a) mechanical properties of the initial material;
- b) microstructure of the initial material and sampling conditions;
- c) further details of the test apparatus;
- d) characteristics of the corrosive substance determined by differential thermal analysis and thermogravimetry, if available.

## Annex A (informative)

### Chemical and electrolytic procedures for removal of corrosion products

#### A.1 General

In the development of this International Standard, a number of sources were consulted to identify chemical and electrolytic descaling procedures. They can be used in addition to those listed in ISO 8407, and they are specifically designed for the purpose of the tests described in this International Standard. This Annex summarizes the results of the survey.

Prior to adopting these procedures, the user should conduct a test on control test pieces to ensure the efficiency of the chosen method. Excess descaling can result in dissolution not only of corrosion products but also of metal substrates.

#### A.2 Procedures

[Table A.1](#) and [Table A.2](#) summarize various chemical and electrolytic procedures for removal of corrosion products. The specific choice of procedure for a given material will depend on many factors, including previous experience.

For all the procedures listed, it is recommended that the surfaces should be maintained vertical during cleaning. This will minimize retention of any gases released during the procedure.

The times specified represent recommendations appropriate for mass-loss studies in the context of Figure 1 in ISO 8407.

When using electrolytic procedures, selecting adequate electrolysis parameters and using blank specimens is recommended, in order to ensure precise removal of corrosion products. A typical setup is shown in [Figure A.1](#).

**WARNING — When working with dangerous substances (such as sodium hydroxide, potassium permanganate, hydrochloric acid), all necessary safety precautions shall be taken.**

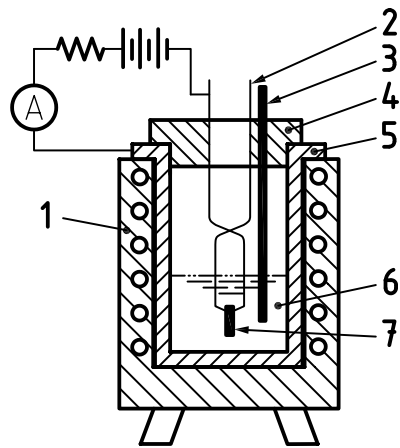

Table A.1 — Chemical procedures for removal of corrosion products

Designation	Material	Chemical agents	Total time	Temperature	Remarks
C.7.10	Heat-resistant stainless steels and superalloys	Step 1: 180 g of sodium hydroxide (NaOH) 30 g of potassium permanganate (KMnO <sub>4</sub> ) Distilled water to make 1 000 ml	30 min to 40 min	boiling	Repetition of step 1 / step-2 / washing is effective for sticky corrosion products
		Step 2: 100 g of ammonium citrate ((NH <sub>4</sub> ) <sub>2</sub> C <sub>6</sub> H <sub>6</sub> O <sub>7</sub> ) Distilled water to make 1 000 ml	30 min to 40 min	boiling	Brushing by soft brush in the middle of treatment is effective
C.3.4	Carbon steels and low-alloy steels	50 ml of hydrochloric acid (HCl, $\rho = 1,19$ g/ml) 0,5 g of hexamethylenetetramine or of 1,3-di- <i>n</i> -butyl-2-thiourea Distilled water to make 1 000 ml	30 min to 40 min	60 °C	Repetition of acid cleaning / washing is effective for sticky corrosion products

Table A.2 — Electrolytic procedures for removal of corrosion products

Designation	Material	Chemical agents	Total time	Temperature	Remarks
E.5.1	Heat-resistant stainless steels and superalloys	Molten salt containing mass fractions of 40 % of sodium hydroxide (NaOH) and 60 % of sodium carbonate (Na <sub>2</sub> CO <sub>3</sub> )	2 min to 5 min	500 °C to 650 °C	Current density of 0,3 to 1,0 A/cm <sup>2</sup> Repetition of electrolysis and washing is effective for sticky scale Brushing by soft brush in the middle of washing is effective Optimization of electrolysis is important



**Key**

- 1 electric furnace
- 2 specimen holder
- 3 thermocouple
- 4 refractory material
- 5 electrolytic bath
- 6 molten salt
- 7 specimen

**Figure A.1 — Typical equipment for the method E.5.1**

## Bibliography

- [1] ISO 17224:—<sup>4)</sup>, *Corrosion of Metals and Alloys — Test method for high temperature corrosion testing of metallic materials by application of a deposit of salt, ash, or other substances*
- [2] ISO 17248:—, *Corrosion of metals and alloys — Test method for high temperature corrosion testing of metallic materials by embedding in salt, ash, or other solids*
- [3] JIS Z2290-2004, *General rules for high-temperature corrosion test of metallic materials*
- [4] JIS Z2293-2004, *Methods for high-temperature corrosion test of metallic materials by dipping and embedding in molten salts*

---

4) To be published.

